

DEUTERIUM ARC LAMP - P717

UV Light Source for Spectroscopy – 10 volt

Instrument

Bas, Biorad, Carlo Erba, Dionex, Dynamax, GBC, IBM, IFCO, Linear, Perspective Biosystems, Scientific Systems Inc, Severn Analytical, Speck Analytical, Spectra Physics, Thermo Fisher, Unicam/Thermo Fisher and Varian.

Electrical

Filament/Heater Voltage	Start	10 VDC
	Operating	5 - 7 VDC
Filament/Heater Current		1.5A Max
Discharge/Arc Voltage	Strike	@25° > 350VDC
	Operating	60 - 90 VDC
Discharge/Arc Current		10 - 300mA
Leads	Black	Filament & Cathode
	Red	Anode
Terminals		3-Pin Housing

Optical

Window	UV Transmitting Borosilicate
Aperture type	1mm Circular
Wavelength range	185nm - 400nm
Noise	< 1×10^{-4} Absorption units
Drift	< 3×10^{-3} Absorption units

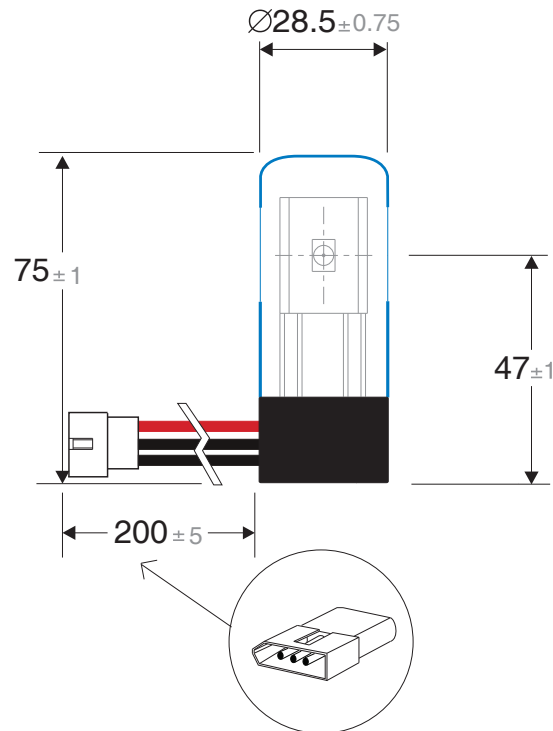

Dimensions in millimetres

Operational life

When radiant energy reaches 50% of the initial energy. Typical life 2000 hours

Deuterium lamps are guaranteed for a period of one year from date of delivery or 2000 hours usage, which ever comes first.

Warranty

Free of charge replacement lamp will be provided where Photron is satisfied the following conditions have been adhered to.

- Lamp is returned to supplier freight paid.
- Lamp has been operated within our recommended specifications.
- Lamp has not failed due to accidental, misuse or transit damage.
- If a replacement lamp is supplied the validity of guarantee shall commence from delivery date of original lamp.

Precautions for use

- Do not subject the lamp to mechanical shock.
- Ensure glass envelope is free from foreign material. Lamp may be wiped using alcohol liquid.
- Caution! UV transmitting window is very thin. Handle with care.
- Care must be taken not to contact lamp with bare hand, temperature can reach over 200°C during operation.
- UV Radiation is harmful to the eyes. Do not observe light output directly.
- Deuterium lamps operate at high voltages. Extreme caution is required to prevent electrical shock.

Spectrum of Deuterium Emissions

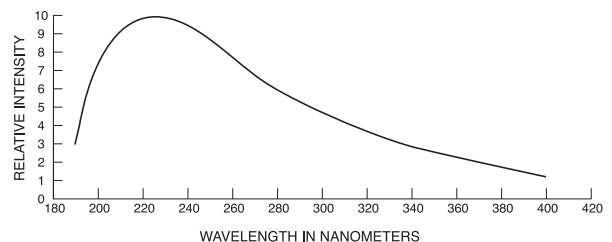

PHOTRON PTY. LTD.
LIGHTEN YOUR HORIZON

Unit 5 - 3 Vesper Drive, Narre Warren, Victoria, Australia 3805

Tel: 6-13-9704-9933 • Fax: 6-13-9704-6289

sales@photron.com.au • service@photron.com.au

www.photronlamp.com

Quality Certified for ISO9001:2000