

# DEUTERIUM ARC LAMP - P707

## UV Light Source for Spectroscopy – 10 volt

### Instrument

Bas, Biorad, Carlo Erba, Dionex, Dynamax, GBC, IBM, IFCO, Linear, Perspective Biosystems, Scientific Systems Inc, Severn Analytical, Speck Analytical, Spectra Physics, Thermo Fisher, Unicam/Thermo Fisher and Varian.

### Electrical

Filament/Heater Voltage	Start	10 VDC
	Operating	5 - 7 VDC
Filament/Heater Current		1.5A Max
Discharge/Arc Voltage	Strike	@25° > 350VDC
	Operating	60 - 90 VDC
Discharge/Arc Current		10 - 300mA
Leads	Black	Filament & Cathode
	Red	Anode
Terminals		3-Pin Housing

### Optical

Window	UV Transmitting Borosilicate
Aperture type	1mm Circular
Wavelength range	185nm - 400nm
Noise	< $1 \times 10^{-4}$ Absorption units
Drift	< $3 \times 10^{-3}$ Absorption units

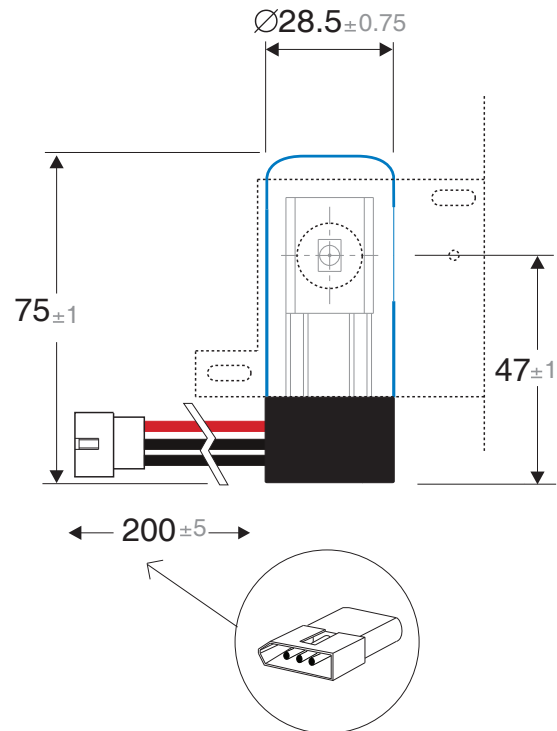

Dimensions in millimetres

### Operational life

When radiant energy reaches 50% of the initial energy. Typical life 2000 hours

Deuterium lamps are guaranteed for a period of one year from date of delivery or 2000 hours usage, which ever comes first.

### Warranty

Free of charge replacement lamp will be provided where Photron is satisfied the following conditions have been adhered to.

- Lamp is returned to supplier freight paid.
- Lamp has been operated within our recommended specifications.
- Lamp has not failed due to accidental, misuse or transit damage.
- If a replacement lamp is supplied the validity of guarantee shall commence from delivery date of original lamp.

### Precautions for use

- Do not subject the lamp to mechanical shock.
- Ensure glass envelope is free from foreign material. Lamp may be wiped using alcohol liquid.
- Caution! UV transmitting window is very thin. Handle with care.
- Care must be taken not to contact lamp with bare hand, temperature can reach over 200°C during operation.
- UV Radiation is harmful to the eyes. Do not observe light output directly.
- Deuterium lamps operate at high voltages. Extreme caution is required to prevent electrical shock.

### Spectrum of Deuterium Emissions

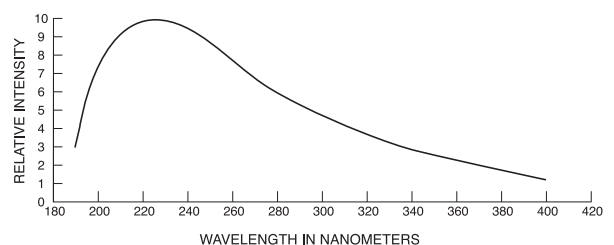

**PHOTRON** PTY. LTD.  
LIGHTEN YOUR HORIZON

Unit 5 - 3 Vesper Drive, Narre Warren, Victoria, Australia 3805

Tel: 6-13-9704-9933 • Fax: 6-13-9704-6289

sales@photron.com.au • service@photron.com.au

www.photronlamp.com

Quality Certified for ISO9001:2000